

■ Features :

- Universal AC input / Full range
- Protections: Short circuit/Over load/Over voltage
- Cooling by free air convection
- 100% full load burn-in test
- Fixed switching frequency at 65KHz
- 2 years warranty

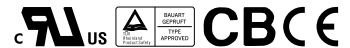

SPECIFICATION

MODEL	CH1	CH2	CH3	
OUTPUT	DC VOLTAGE	3.3V	5V	12V
	RATED CURRENT	4A	4A	1A
	CURRENT RANGE	0 ~ 5A	0.2 ~ 7A	0 ~ 1.2A
	RATED POWER	Total power max. 45.2W(CH1+CH2 max. 35W)		
	RIPPLE & NOISE (max.) Note.2	50mVp-p	50mVp-p	100mVp-p
	VOLTAGE ADJ. RANGE	CH1: 3 ~ 3.6V		
	VOLTAGE TOLERANCE Note.3	±2.0%	+4,-2%	±8.0%
	LINE REGULATION	±1.0%	±1.0%	±2.0%
LOAD REGULATION	±2.0%	±2.0%	±8.0%	
SETUP, RISE, HOLD TIME	800ms, 50ms, 16ms at full load			
INPUT	VOLTAGE RANGE	90 ~ 264VAC 127 ~ 370VDC		
	FREQUENCY RANGE	47 ~ 63Hz		
	EFFICIENCY(Typ.)	72%		
	AC CURRENT	1.2A/115VAC 0.7A/230VAC		
	INRUSH CURRENT(max.)	COLD START 20A/115V 40A/230V		
	LEAKAGE CURRENT	<1mA/ 240VAC		
PROTECTION	OVER LOAD	120 ~ 160% rated output power Protection type : Hiccup mode, recovers automatically after fault condition is removed		
	OVER VOLTAGE	5.75 ~ 6.75V on +5V Protection type : Hiccup mode, recovers automatically after fault condition is removed		
ENVIRONMENT	WORKING TEMP.	-10 ~ +60°C (Refer to output load derating curve)		
	WORKING HUMIDITY	20 ~ 90% RH non-condensing		
	STORAGE TEMP., HUMIDITY	-20 ~ +85°C, 10 ~ 95% RH		
	TEMP. COEFFICIENT	±0.03%/°C (0 ~ 50°C)		
	VIBRATION	10 ~ 500Hz, 2G 10min./1cycle, Period for 60min.each along X, Y, Z axes		
SAFETY & EMC (Note 4)	SAFETY STANDARDS	UL1950, TUV EN60950 Approved		
	WITHSTAND VOLTAGE	I/P-O/P:3KVAC I/P-FG:1.5KVAC O/P-FG:0.5KVAC 1min.		
	ISOLATION RESISTANCE	I/P-O/P, I/P-FG, O/P-FG:100M Ohms/500VDC		
	EMI CONDUCTION & RADIATION	Compliance to EN55022 (CISPR22) Class B		
	HARMONIC CURRENT	Compliance to EN61000-3-2,-3		
OTHERS	EMM IMMUNITY	Compliance to EN61000-4-2,3,4,5,6,11 Light industry level, criteria A		
	MTBF	220.9Khrs min. MIL-HDBK-217F (25°C)		
	DIMENSION	127*76.2*28mm (L*W*H)		
	PACKING	0.23Kg; 72pcs/16.6Kg/1.35CUFT		
NOTE	<ol style="list-style-type: none"> 1. All parameters NOT specially mentioned are measured at 230VAC input, rated load and 25°C of ambient temperature. 2. Ripple & noise are measured at 20MHz of bandwidth by using a 12" twisted pair-wire terminated with a 0.1uF & 47uF parallel capacitor. 3. Tolerance : includes set up tolerance, line regulation and load regulation. 4. The power supply is considered a component which will be installed into a final equipment. The final equipment must be re-confirmed that it still meets EMC directives. 5. Mounting holes M1 and M2 should be grounded for EMI purposes. 			

Mechanical Specification

Unit:mm

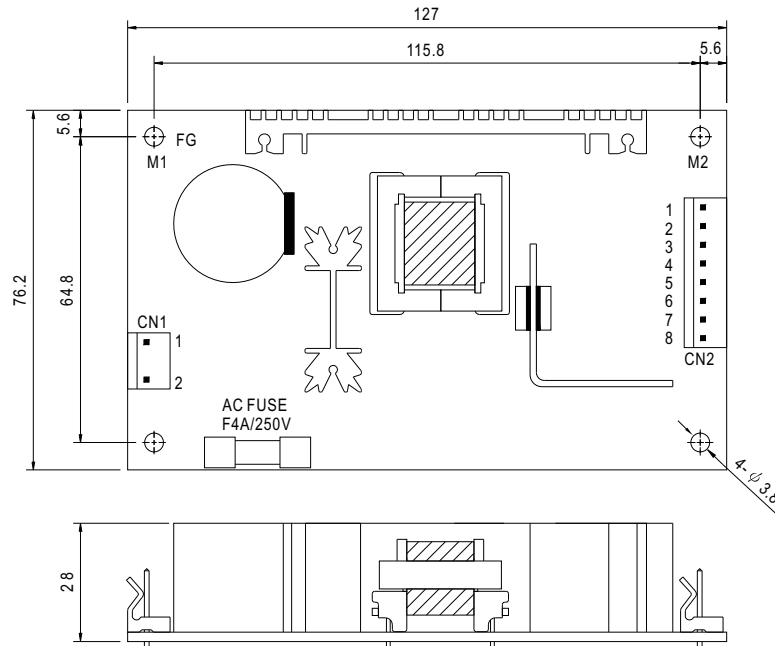

AC Input Connector (CN1) : Molex 5277-02 or equivalent

Pin No.	Assignment	Mating Housing	Terminal
1	AC/N	Molex 5195 or equivalent	Molex 5194 or equivalent
2	AC/L	Molex 5195 or equivalent	Molex 5194 or equivalent

DC Output Connector (CN2) : Molex 5273-08 or equivalent

Pin No.	Assignment	Mating Housing	Terminal
1,2	+5V	Molex 5195 or equivalent	Molex 5194 or equivalent
3,4,5	COM		
6	+V		
7,8	+3.3V		

Block Diagram

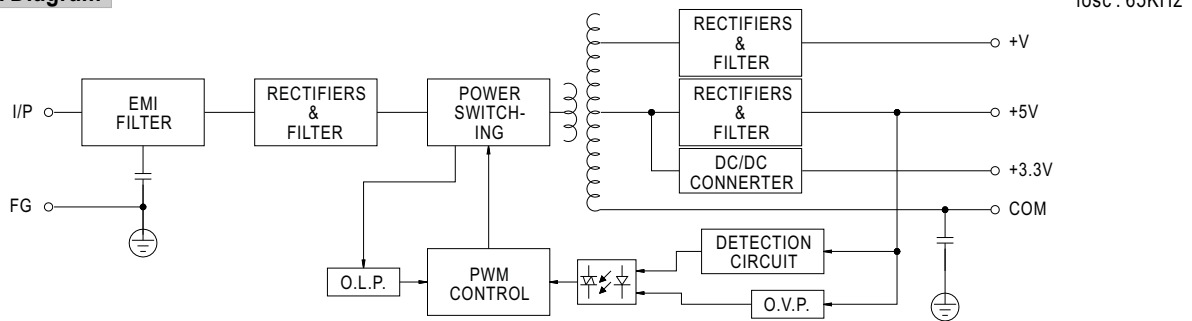

Output Derating

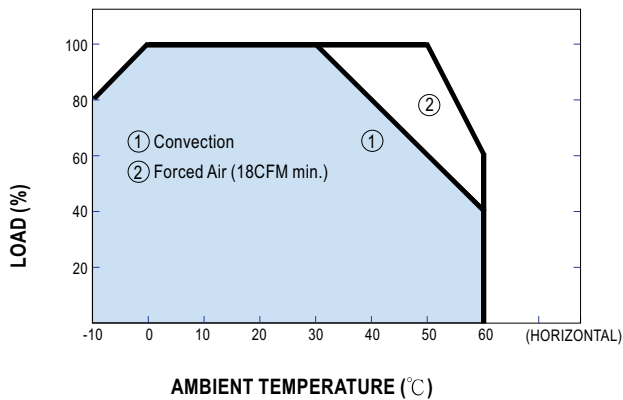

Static Characteristics

