



### ■ Features :

- AC input range selectable by switch
- Protections: Short circuit/Over load/Over voltage/Over temperature
- 100% full load burn-in test
- Fixed switching frequency at 90KHz
- Low cost
- High reliability
- 2 years warranty



### SPECIFICATION

MODEL	S-210-5	S-210-7.5	S-210-12	S-210-13.5	S-210-15	S-210-24	S-210-27	S-210-48		
OUTPUT	DC VOLTAGE	5V	7.5V	12V	13.5V	15V	24V	27V	48V	
	RATED CURRENT	40A	27A	17A	15A	14A	8.8A	7.8A	4.4A	
	CURRENT RANGE	0 ~ 40A	0 ~ 27A	0 ~ 17A	0 ~ 15A	0 ~ 14A	0 ~ 8.8A	0 ~ 7.8A	0 ~ 4.4A	
	RATED POWER	200W	202.5W	204W	202.5W	210W	211.2W	210.6W	211.2W	
	RIPPLE & NOISE (max.) Note.2	80mVp-p	100mVp-p	120mVp-p	120mVp-p	120mVp-p	200mVp-p	200mVp-p	200mVp-p	
	VOLTAGE ADJ. RANGE	4.5 ~ 5.7V	6 ~ 9V	10 ~ 13.2V	12 ~ 15V	13.5 ~ 18V	20 ~ 26.4V	26 ~ 29V	45.6 ~ 52.8V	
	VOLTAGE TOLERANCE Note.3	±2.0%	±2.0%	±1.0%	±1.0%	±1.0%	±1.0%	±1.0%	±1.0%	
	LINE REGULATION	±0.5%	±0.5%	±0.5%	±0.5%	±0.5%	±0.5%	±0.5%	±0.5%	
	LOAD REGULATION	±1.0%	±1.0%	±0.5%	±0.5%	±0.5%	±0.5%	±0.5%	±0.5%	
	SETUP, RISE TIME	1000ms, 20ms/230VAC      1000ms, 20ms/115VAC at full load								
HOLD TIME (Typ.)	20ms/230VAC      20ms/115VAC at full load									
INPUT	VOLTAGE RANGE	88 ~ 132VAC / 176~264VAC by switch      248 ~ 370VDC								
	FREQUENCY RANGE	47 ~ 63Hz								
	EFFICIENCY (Typ.)	79%	82%	83%	84%	85%	87%	87%	87%	
	AC CURRENT (Typ.)	4.2A/115VAC      2.5A/230VAC								
	INRUSH CURRENT (Typ.)	35A/115VAC      50A/230VAC								
	LEAKAGE CURRENT	<3.5mA / 240VAC								
PROTECTION	OVER LOAD	105 ~ 150% rated output power Protection type : Hiccup mode, recovers automatically after fault condition is removed								
	OVER VOLTAGE	5.75 ~ 6.75V	9.4 ~ 10.9V	13.8 ~ 16.2V	15.5 ~ 18.2V	18 ~ 21V	27.6 ~ 32.4V	31.05 ~ 36.45V	55.2 ~ 64.8V	
	OVER TEMPERATURE	RTH1 ≥ 85°C Protection type : Shut down o/p voltage, recovers automatically after temperature goes down								
ENVIRONMENT	WORKING TEMP.	-20 ~ +50°C (Refer to output load derating curve)								
	WORKING HUMIDITY	20 ~ 90% RH non-condensing								
	STORAGE TEMP., HUMIDITY	-40 ~ +85°C, 10 ~ 95% RH								
	TEMP. COEFFICIENT	±0.03%/°C (0 ~ 50°C)								
	VIBRATION	10 ~ 500Hz, 2G 10min./1cycle, Period for 60min. each along X, Y, Z axes								
SAFETY & EMC	SAFETY STANDARDS	UL60950-1 Approved								
	WITHSTAND VOLTAGE	I/P-O/P:3KVAC      I/P-FG:1.5KVAC      O/P-FG:0.5KVAC								
	ISOLATION RESISTANCE	I/P-O/P, I/P-FG, O/P-FG:100M Ohms/500VDC								
OTHERS	MTBF	244.7K hrs min.      MIL-HDBK-217F (25°C)								
	DIMENSION	215*115*50mm (L*W*H)								
	PACKING	0.95Kg; 12pcs/12.4Kg/0.92CUFT								
NOTE	<ol style="list-style-type: none"> <li>1. All parameters NOT specially mentioned are measured at 230VAC input, rated load and 25°C of ambient temperature.</li> <li>2. Ripple &amp; noise are measured at 20MHz of bandwidth by using a 12" twisted pair-wire terminated with a 0.1uF &amp; 47uF parallel capacitor.</li> <li>3. Tolerance : includes set up tolerance, line regulation and load regulation.</li> </ol>									

**Mechanical Specification**

Case No. 912E Unit:mm

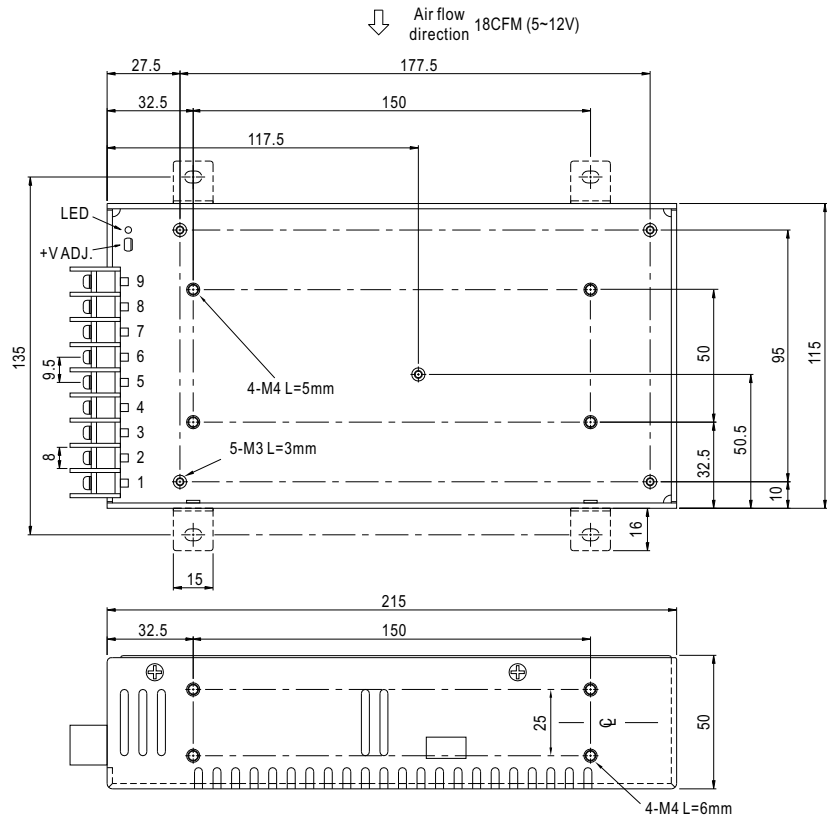

Terminal pin number assignment :

Pin No.	Assignment	Pin No.	Assignment
1	AC/L	4~6	DC OUTPUT -V
2	AC/N	7~9	DC OUTPUT +V
3	FG $\perp$		

**Block Diagram**

fosc : 90KHz

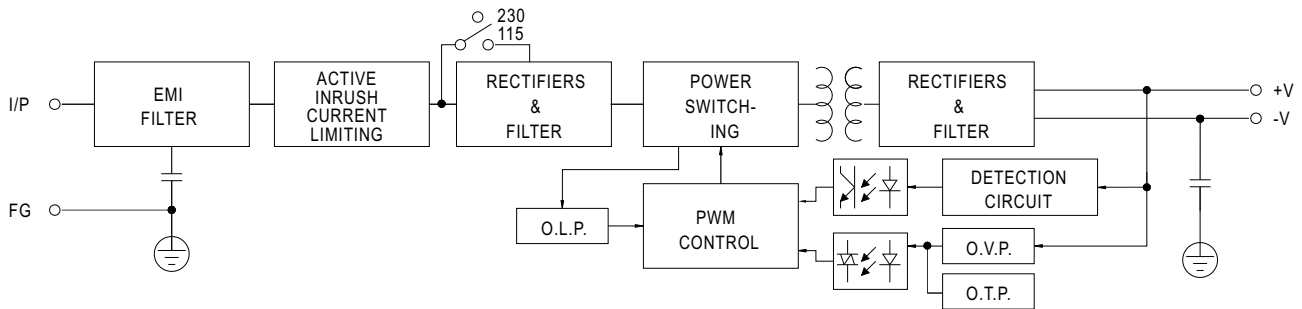

**Derating Curve**

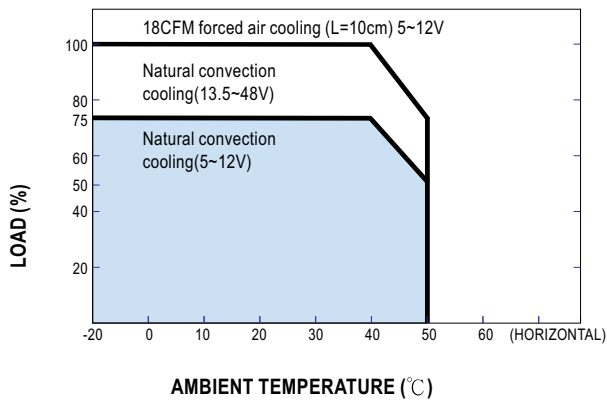

**Static Characteristics**

