



■ Features :

- AC input 200~260VAC, 3 $\phi$  3wires (other system available)
- Protections: Short circuit/ Over voltage/ Over load/ Over temp.
- High reliability; Low ripple noise
- Built-in remote sense function
- Built-in remote ON-OFF control
- With parallel function
- Can adjust from 20~100% output voltage by external control 1-5V
- Forced air cooling by built-in DC fan
- Case coating with paint
- 2 years warranty

Parallel

## SPECIFICATION

ORDER NO.	SCN-2K0-05	SCN-2K0-12	SCN-2K0-15	SCN-2K0-24	SCN-2K0-48	
OUTPUT	SAFETY MODEL NO.	2K0S-N005	2K0S-N012	2K0S-N015	2K0S-N024	2K0S-N048
	DC VOLTAGE	5V	12V	15V	24V	48V
	RATED CURRENT	250A	167A	134A	83.5A	42A
	CURRENT RANGE	0 ~ 250A	0 ~ 167A	0 ~ 134A	0 ~ 83.5A	0 ~ 42A
	RATED POWER	1250W	2000W	2000W	2000W	2000W
	RIPPLE & NOISE (max.) Note.2	150mVp-p	180mVp-p	200mVp-p	240mVp-p	480mVp-p
	VOLTAGE ADJ. RANGE	$\pm 5.0\%$ typical adjustment by potentiometer 20~100% adjustment by 1~5VDC external control				
	VOLTAGE TOLERANCE Note.3	$\pm 3.0\%$	$\pm 2.0\%$	$\pm 2.0\%$	$\pm 1.0\%$	$\pm 1.0\%$
	LINE REGULATION	$\pm 0.5\%$	$\pm 0.5\%$	$\pm 0.5\%$	$\pm 0.5\%$	$\pm 0.5\%$
	LOAD REGULATION	$\pm 2.5\%$	$\pm 1.5\%$	$\pm 1.5\%$	$\pm 0.5\%$	$\pm 0.5\%$
SETUP, RISE, HOLD TIME	800ms, 50ms, 16ms at full load					
INPUT	VOLTAGE RANGE	200 ~ 260VAC, 3 $\phi$ , 3wires				
	FREQUENCY RANGE	47~63Hz				
	EFFICIENCY (Typ.)	78%	84%	84%	85%	86%
	AC CURRENT	9.5A / 230VAC @ VL				
	INRUSH CURRENT (max.)	120A / 230VAC				
	LEAKAGE CURRENT (max.)	5mA / 240VAC				
PROTECTION	OVER LOAD	101~115%	110~135% rated output power			
		Protection type : Current limiting, delay shut down o/p voltage, re-power on to recover				
	OVER VOLTAGE	110~135% follow to output set up point				
	Protection type : Shut down o/p voltage, re-power on to recover					
OVER TEMPERATURE	>100 $^{\circ}$ C / measure by heat sink, near transformer					
	Protection type : Shut down o/p voltage, re-power on to recover					
ENVIRONMENT	WORKING TEMP.	-10~+65 $^{\circ}$ C (Refer to output load derating curve)				
	WORKING HUMIDITY	20%~90% RH non-condensing				
	STORAGE TEMP., HUMIDITY	-20~+85 $^{\circ}$ C 10~95% RH				
	TEMP. COEFFICIENT	$\pm 0.04\%$ / $^{\circ}$ C (0~50 $^{\circ}$ C)				
	VIBRATION	10~200Hz, 2G 10min./1cycle, period for 60min. each along X, Y, Z axes				
SAFETY & EMC (Note. 4)	SAFETY STANDARDS	Design refer to UL1950, CSA22.2, IEC60950				
	WITHSTAND VOLTAGE	I/P-O/P:1500VAC, I/P-FG:1500VAC				
	ISOLATION RESISTANCE	I/P-O/P, I/P-FG, >100M Ohms / 500VDC				
	EMI CONDUCTION & RADIATION	Design refer to FCC part 15 class A				
	HARMONIC CURRENT	----				
	EMS IMMUNITY	----				
OTHERS	MTBF	30khrs min. MIL-HDBK-217F (25 $^{\circ}$ C)				
	DIMENSION	320*212*134mm (L*W*H)				
	PACKING	9.0kg; 1pcs/ 10kg / CARTON				
	SPECIAL FUNCTION	DC voltage adj., Remote sensing, remote control, parallel operation (refer to terminal instruction manual)				
NOTE	<p>1. All parameters are specified at 230VAC input, rated load, 25<math>^{\circ}</math>C 70% RH. Ambient.</p> <p>2. Tolerance: includes set up tolerance, line regulation, load regulation.</p> <p>3. Ripple &amp; noise are measured at 20MHz by using a 12" twisted pair terminated with a 0.1uf &amp; 47uf capacitor.</p> <p>4. The power supply is considered a component which will be installed into a final equipment. The final equipment must be re-confirmed that it still meets EMC directives.</p>					

## Mechanical Specification

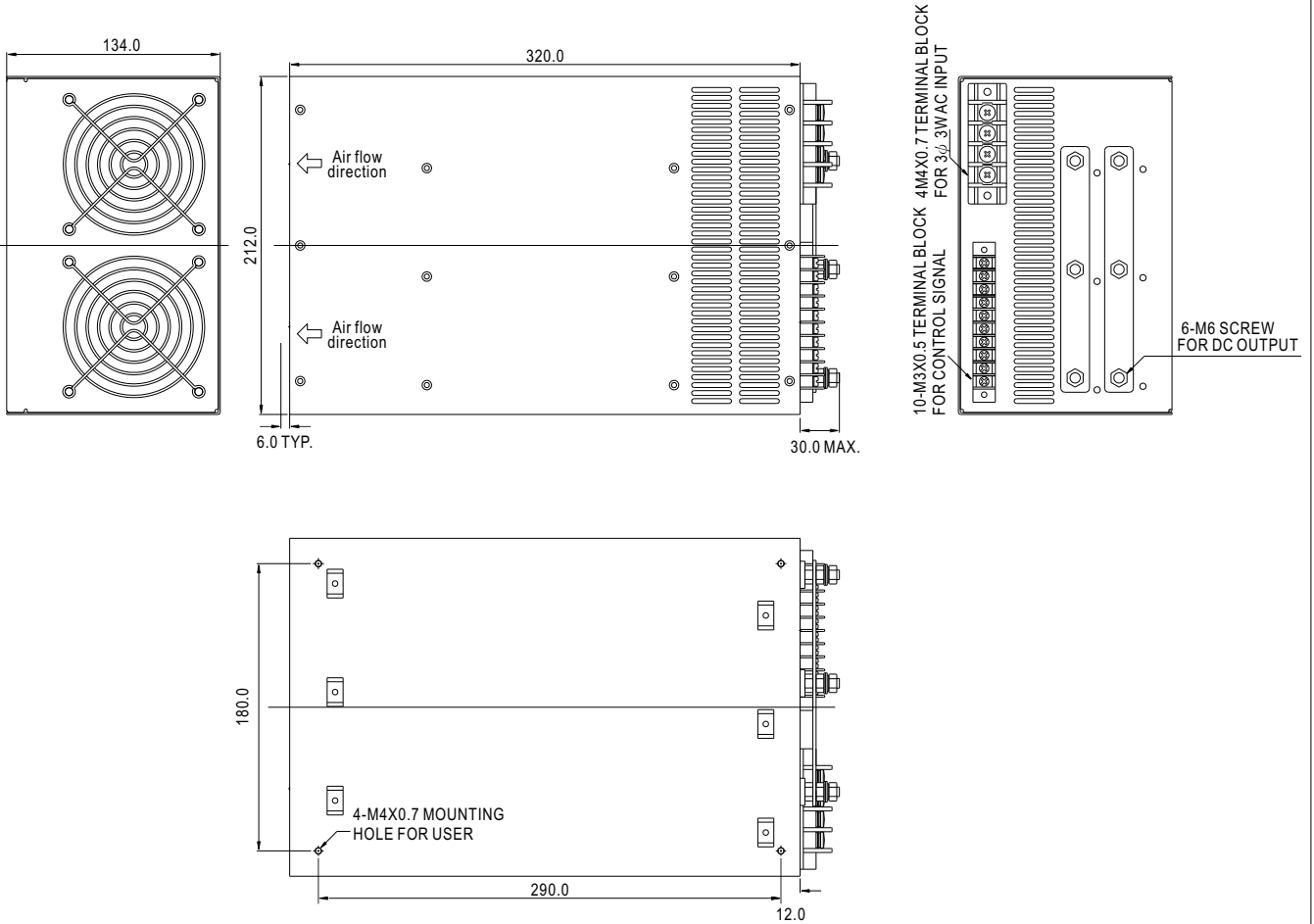

## Derating Curve

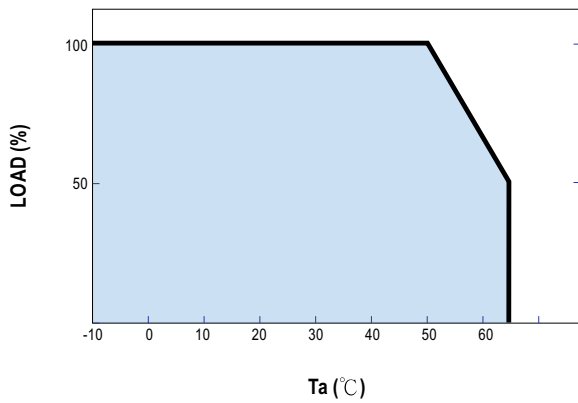

## External DC Control VS Output Voltage

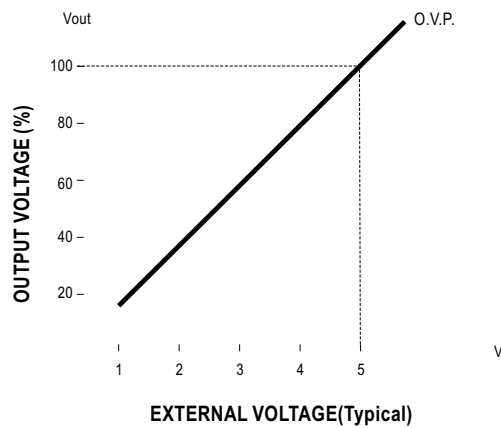

■ Control terminal instruction manual

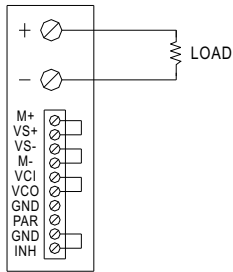

USING INTERNAL VOLTAGE CONTROL

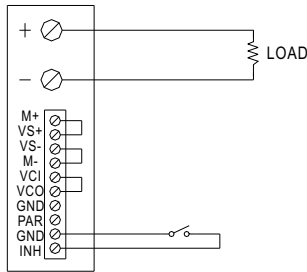

ON/OFF CONTROL SWITCH

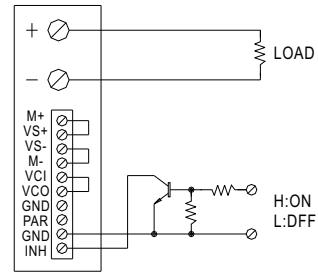

ON/OFF CONTROL BY TRANSISTOR

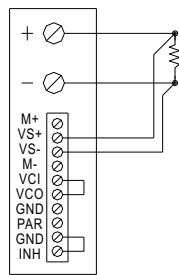

REMOTE SENSING

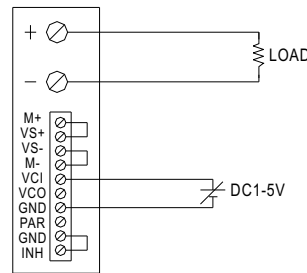

OUTPUT VOLTAGE ADJUST WITH DC 1-5V

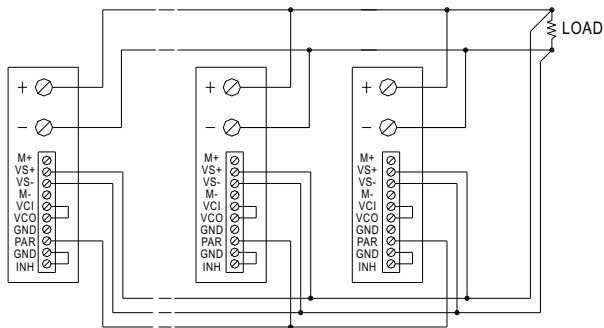

PARALLEL OPERATION WITH REMOTE SENSING

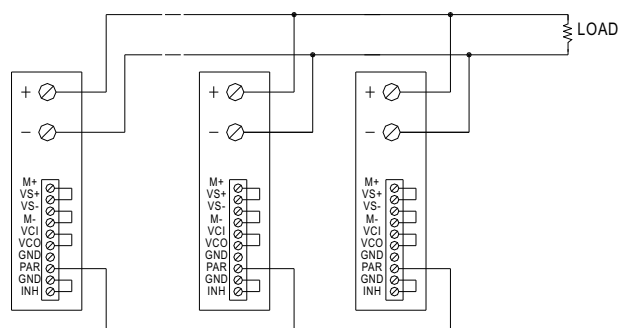

PARALLEL OPERATION

■ FIG. A: 3  $\phi$  3W 220VAC SYSTEM (STANDARD MODEL FOR STOCK)

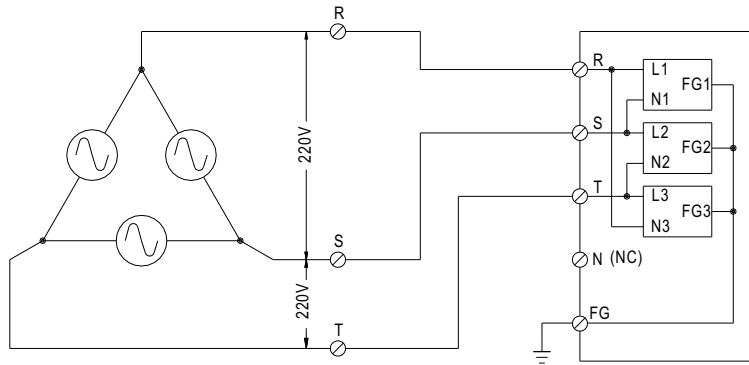

■ FIG. B: 1  $\phi$  220VAC SYSTEM

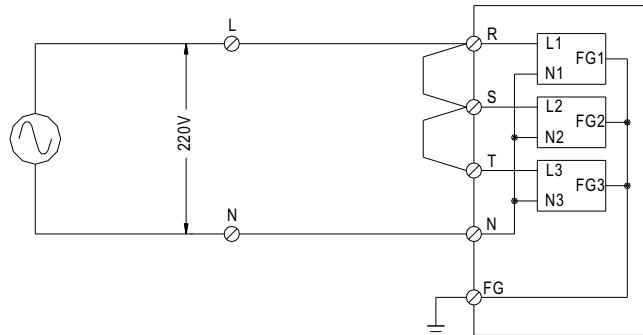

■ FIG. C: 3  $\phi$  4W 220/380VAC SYSTEM

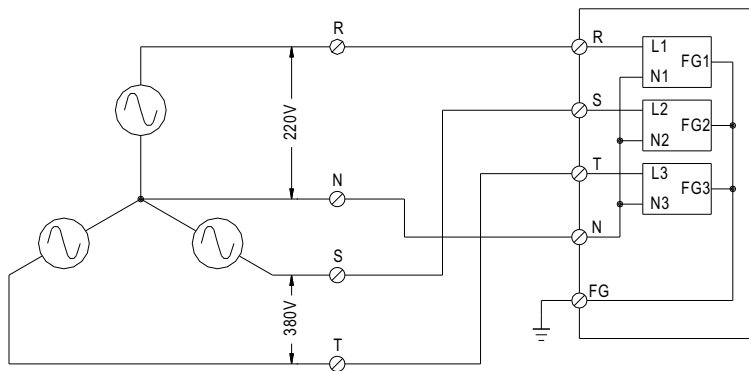

■ FIG. D: 3  $\phi$  4W 190/110VAC SYSTEM

